



EXERCYCLE

Inspired by the road.
Designed for cyclists.

BHFITNESS

exercycle.bhfitness.com



The Exercycle is the result of the collaboration between the BH Fitness and BH Bikes R&D teams to meet the home-workout demands of the road bike enthusiast. Faced with the current alternatives of either riding a trainer or using the classic indoor cycle bike on days when the weather is bad, the Exercycle offers the most familiar feeling.

Its geometry, based on the BH Aerolight, offers ergonomics and a postural feeling very similar to that of a road bike. With attention to every last detail, it is a product that offers multiple options so that the cyclist can enjoy a hyper-realistic experience while training at home. The possibility of using your own saddle, pedal changes or adjustment systems to adapt organically to the user's constitution will make this bike the ideal complement for the harshest winter months.

BH breaks down the barriers between training at home and outdoor routes to offer users the best experience while practicing their favorite sport.







Design

Design has been one of the main pillars of the Exercycle development process. Which is why we have proposed a sober and minimalist design, adapted to the latest trends in industrial design, with organic shapes and matt finishes. The sobriety of the bike enhances its shapes and volumes, without burying in with flashy decorations. We want you to see it for what it is: your second bike.



EMS resistance system.

The electromagnetic resistance system allows a very precise and progressive regulation of intensity, while generating a pedal stroke sensation very similar to the resistance of tarmac on wheels.

It is a widely used system in the medical-sports field but it is not traditionally applied to indoor cycle bikes, where the goal is simply raw resistance, without paying attention to the sensations while pedalling.

High accuracy in watt measurement.

Measuring the watts generated during training is key for any bike lover. For this reason, we have dedicated a great deal of effort to incorporating an extremely precise measurement system, which allows users to have absolute control of their training parameters.



Q factor of 152.

The Q factor is the distance between the axles of the bike's cranks. It is one of the determining factors when it comes to being able to replicate a position similar to that of the road bike, and one of the weak points of home training machines. This has been precisely one of the workhorses of the Exercycle development team, who have managed to obtain a Q factor of 152, one of the lowest on the market, which allows the position of the legs during pedalling to be very similar to that of the road bike, while allowing the user to generate maximum force with each pedal stroke.

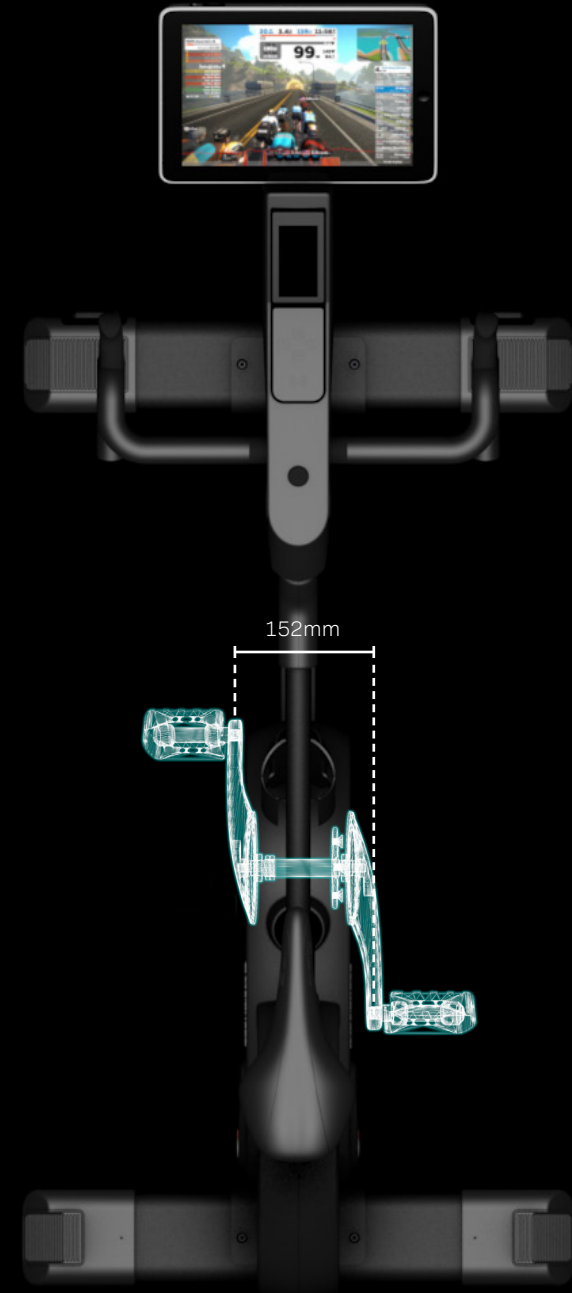



Geometry based on the Aerolight™.

The careful design of the frame allows great adaptability of the bike to the user, simulating the position on a road bike. The V-frame design allows the bike to fit sizes from S to XL, ensuring the highest degree of performance during exercise.

**INSPIRED
BY THE
ROAD.
DESIGNED
FOR
CYCLISTS.**



Resistance change integrated into the handlebar.

As well as being one of the most automated gestures any cyclist can have and providing a more realistic feel during exercise, handlebar shifting has a practical function: giving the user the ability to change resistance without changing their posture.



Instantaneous values

The first screen displays instant exercise data.



Percentage values

The second screen shows percentages for the test.



Average values

A third screen shows the average values for the current session.



Maximum values

The last screen offers the user the maximum values obtained during training.

Multiscreen monitor

The Exercycle has a multi-screen LCD monitor with all the necessary functions for a complete workout.

It has an FTP test to calculate the watt threshold, a 5KHz Polar telemetric pulse receiver and a Bluetooth FTMS module that enables full compatibility with leading cycling simulators.



Full connectivity.

The Exercycle offers the latest technology in connectivity, so you can compete with your teammates using the multiple simulation applications on the market. This is achieved thanks to the integrated Bluetooth FTMS module in the bike's console, which allows full compatibility with industry-leading applications.

You can enjoy the experience of training with the main cycling simulators such as **Zwift**, **Kinomap**, **Rouvy** or **Bkool**, turning gray winter afternoons into exciting experiences, competing against other users, or the rewarding feeling of training in legendary cycling ports such as Tourmalet or the Alpe d'Huez



Technical data

Length	140-144 cm	Handlebar width	42 cm
Width	61 cm	Q Factor	152 mm
Height	114-136 cm	Power adjustment	2 positions
Weight	48,6 Kg	Shifting	Electronic sequential shifting on levers and monitor
Flywheel	11 Kg EMS	Saddle	BH ergo-g ng afm cromo
Resistance System	Electromagnetic EMS	Pedals	Wellgo wpd 981 mixed
Connectivity	Compatible with iOS, Mac OS y Android Bluetooth FTMS	Interchangeable pedals	Yes
Compatible Apps	  	Interchangeable saddle	Yes
Transmission	Heavy duty belt with automatic tensioner	Transport wheels	Rollers
Gradient	0-25%	Max user weight	150 Kg
Maximum Watts	1500W real*	Use frequency	Intensive
Resistance levels	24	Tablet/mobile holder	Up to 12,9"

*Watts obtained in realistic developments.

Size and measurements

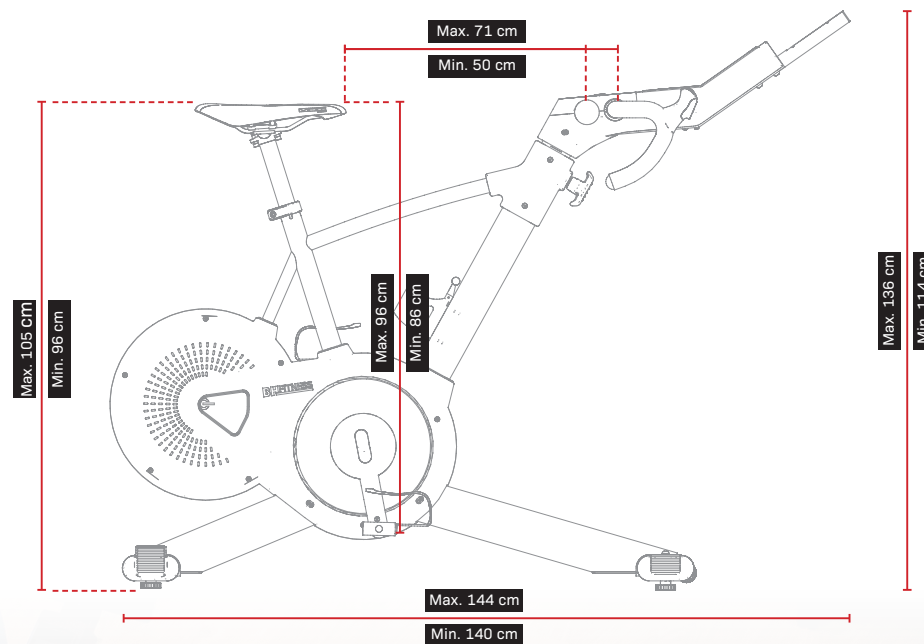

C EXERCYCLE

BHFITNESS